

PRODUCT NUMBER  
SEE TABLE, SHT 3

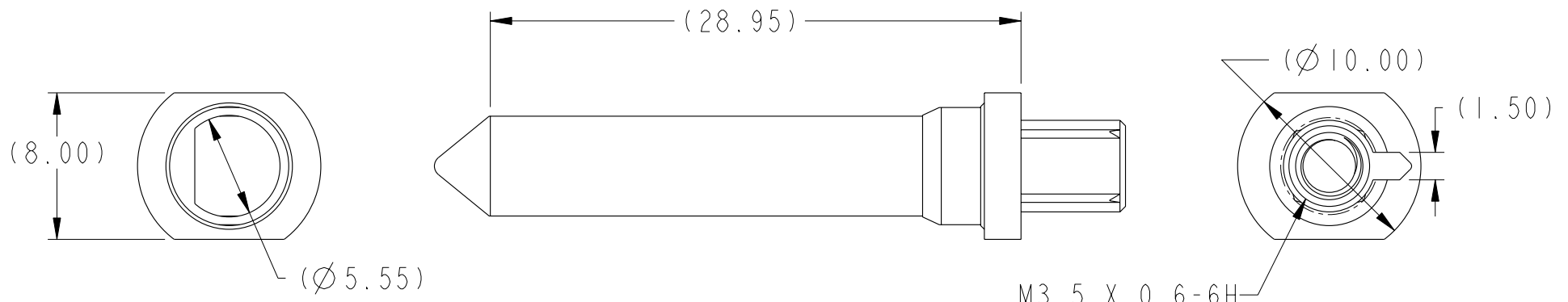

M3.5 X 0.6-6H  
SEE TABLE DIM "D"  
FOR THREAD DEPTH

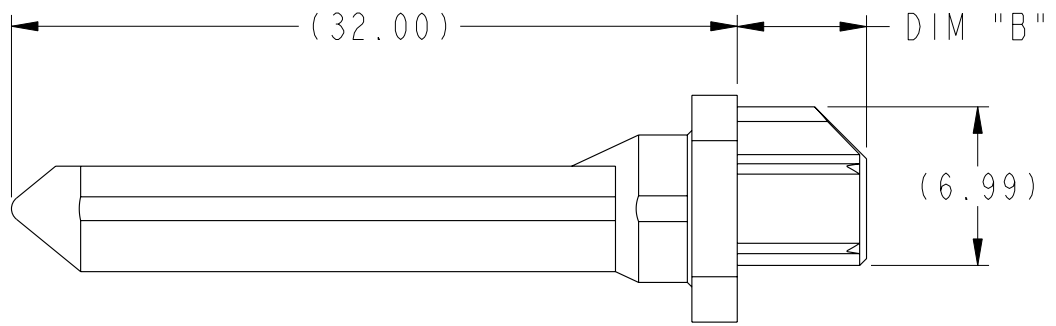

Copyright FCI.

rev	ecn no	dr	date
A	V05-0103	AR	2005-01-27
B	V05-0228	AR	2005-03-11
C	V05-0241	AR	2005-03-15
D	V05-0262	AR	2005-03-29
E	S05-0237	CH	2005-08-23
F	S06-0045	CH	2006-01-25
G	S08-0112	CH	2008-04-14

www.fciconnect.com		surface 3.200 ASME Y14.5	tolerance std ASME Y14.5	projection MM
TOLERANCES UNLESS OTHERWISE SPECIFIED		ANGULAR	LINEAR	size A4
Dr	A. RAISTRICK	2004-08-03	0.X ±0.3	Scale 3:1
Eng	B. MARSHALL	2004-08-03	0.XX ±0.10	ECN ***
Chr	C. H. TAN	2008-05-05	0.XXX ±0.05	Spec ref -
Appr	JOEY NG	2008-05-05	Product Affinity Accessories	
FCI		10.8mm GUIDE PIN, INTERNAL THREAD		dwg no 10037911
catalog no		-		Rev. G
		CUSTOMER		sheet 1 of 3

REV F - 2006-04-17



Copyright FCI.

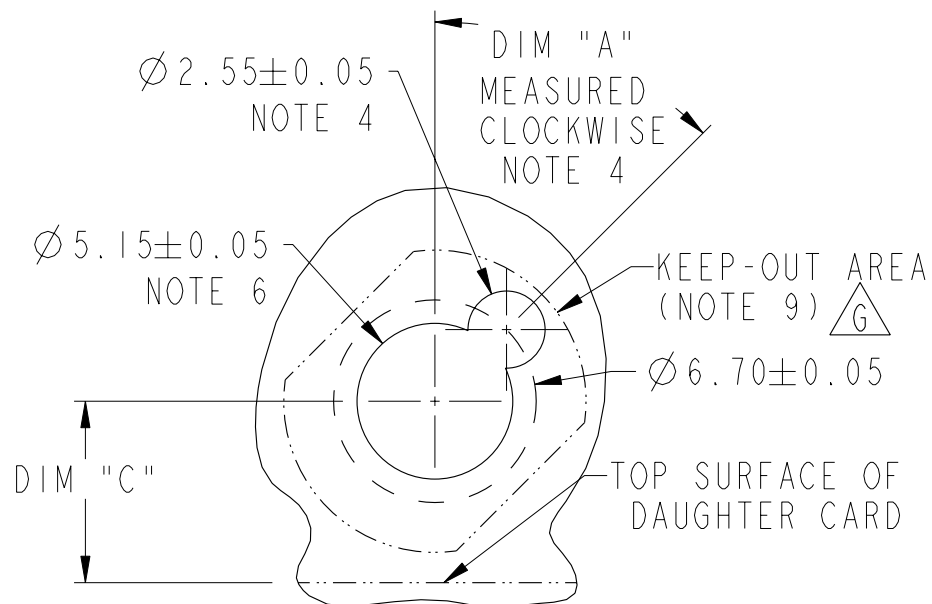

RECOMMENDED PCB LAYOUT(DRILLING)  
 NOTES 4,5 & 6   
 SCALE 4:1

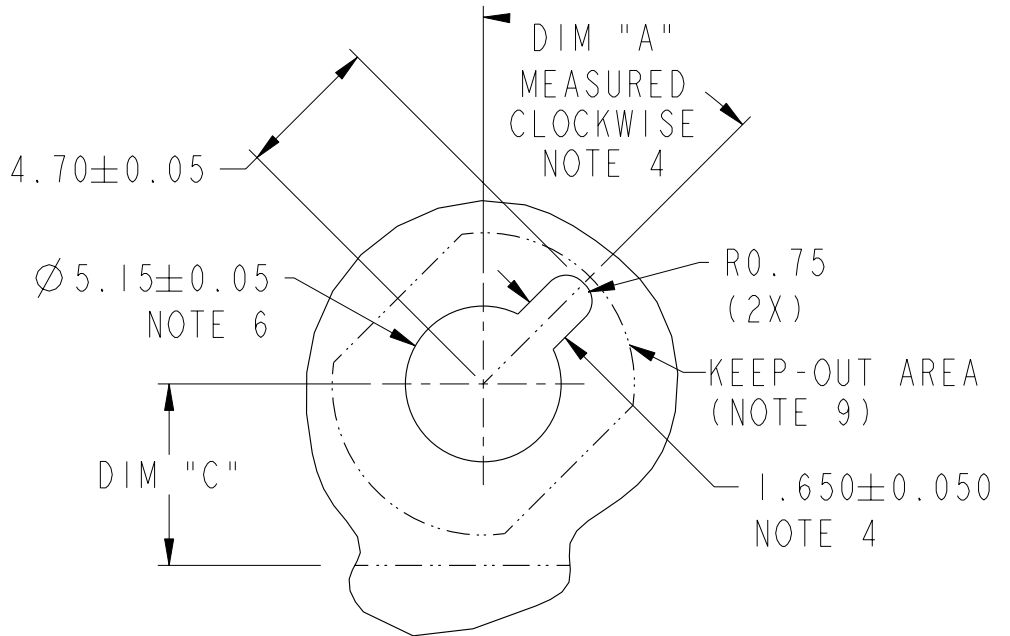

RECOMMENDED PCB LAYOUT(MILLING)  
 NOTE 4,5 & 6   
 SCALE 4:1

10.8 MM RECEPTACLE GUIDE MODULE NOTE 4	DIM "A"
10037912-1X1LF	0°
10037912-1X2LF	45°
10037912-1X3LF	90°
10037912-1X4LF	135°
10037912-1X5LF	180°
10037912-1X6LF	225°
10037912-1X7LF	270°
10037912-1X8LF	315°



title 10.8mm GUIDE PIN, INTERNAL THREAD	dwg no 10037911	Rev. G

PRODUCT NUMBER	DIM "B"	DIM "C" 4/5 PAIR	DIM "C" 2/3 PAIR	DIM "D"
10037911-101LF	5.70	6.00	4.50	6.60
10037911-102LF	2.75	6.00	4.50	4.10
10037911-103LF	3.20	6.00	4.50	4.10
10037911-104LF	2.40	6.00	4.50	4.10

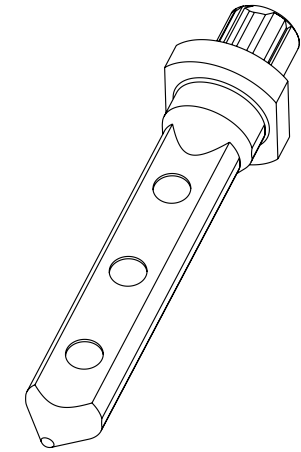

1. MATERIAL: ZINC ALLOY
2. FINISH: ZINC YELLOW CHROMATE
3. APPLICATION SPECIFICATION: GS-20-045
- ④ KEY HOLE ORIENTATION (DIM "A") WILL BE DEFINED BY THE MATING RECEPTACLE GUIDE MODULE PART NUMBER - SEE TABLE (ORIENTATION SHOWN IS FOR 10037912-1X2LF)
- ⑤ REFER TO CUSTOMER DRAWING 10035911 FOR INFORMATION REGARDING PCB LAYOUT OF POWER AND GUIDE MODULES RELATIVE TO SIGNAL MODULES
- ⑥ THRU HOLE PLATING AND ANNULAR RINGS MUST BE ADDED IN APPLICATIONS THAT USE THE ESD GROUNDING OPTION FINISHED HOLE SIZE IS THE SAME REGARDLESS OF PLATED BARREL OR NOT.
7. THIS PRODUCT MEETS EUROPEAN UNION DIRECTIVES AND OTHER COUNTRY REGULATIONS AS DESCRIBED IN GS-22-008.
8. PACKAGING MEETS GS-14-920 LEAD FREE LABELING SPECIFICATION.
- △G ⑨ KEEP OUT ZONE MATCH PROFILE OF SEATED GUIDE PIN, SEE SHEET 1 FOR REFERENCE DIMENSIONS OF GUIDE PIN OUTLINE.
- △G 10. A △G SYMBOL WILL BE NEXT TO ANY DIMENSION, VIEW OR NOTE WHICH HAS BEEN MODIFIED WITH THE CURRENT DRAWING REVISION.



Copyright FCI.

FCI	title	10.8mm GUIDE PIN, INTERNAL THREAD	dwg no	10037911	Rev.	G
	catalog no	-	CUSTOMER	sheet 3 of 3		